

4 WIRING DIAGRAM

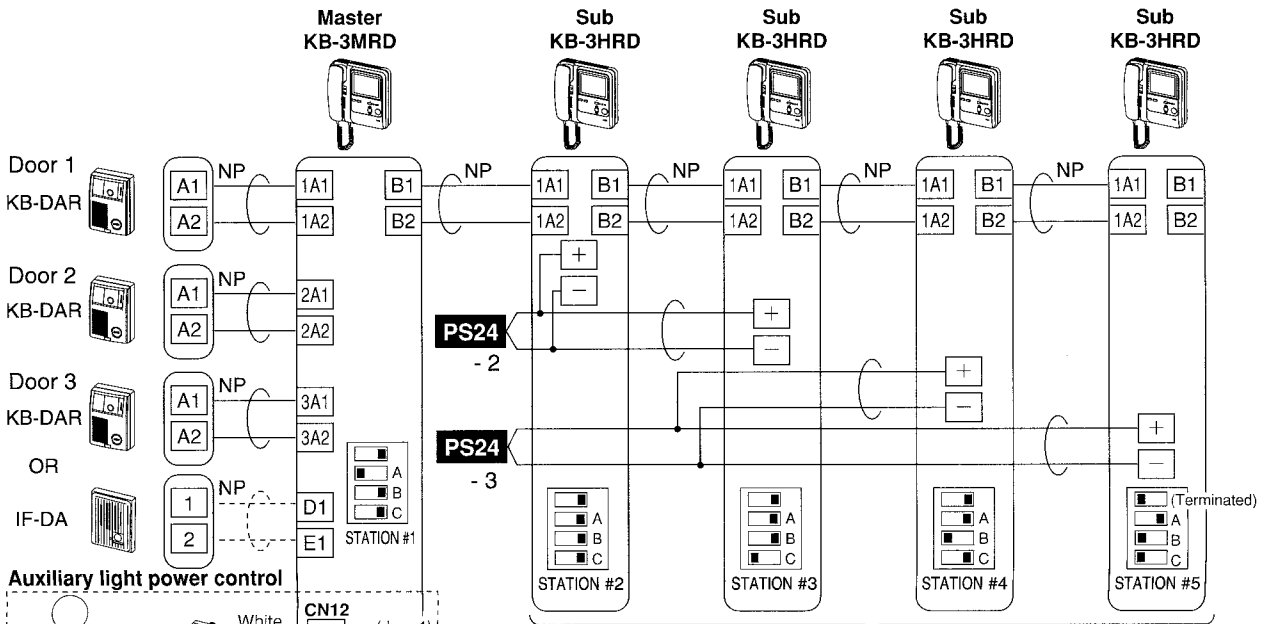

See 5. MOUNTING Item 5 on Page 7.

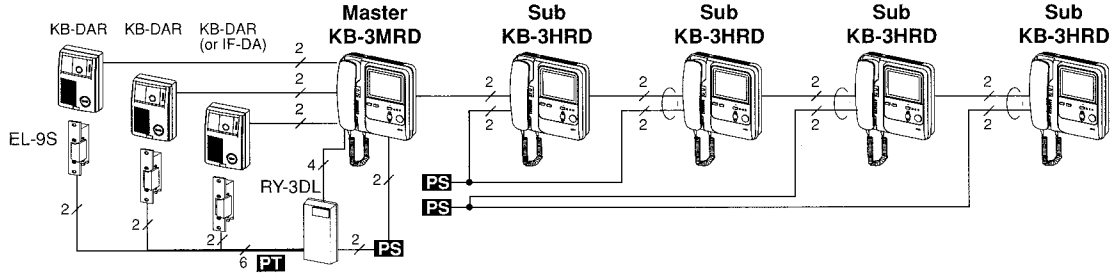
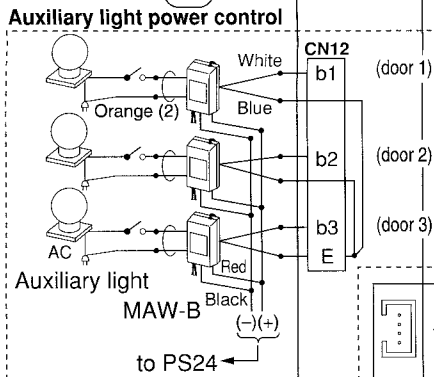

Connectors for optional devices (supplied with KB-3MRD)

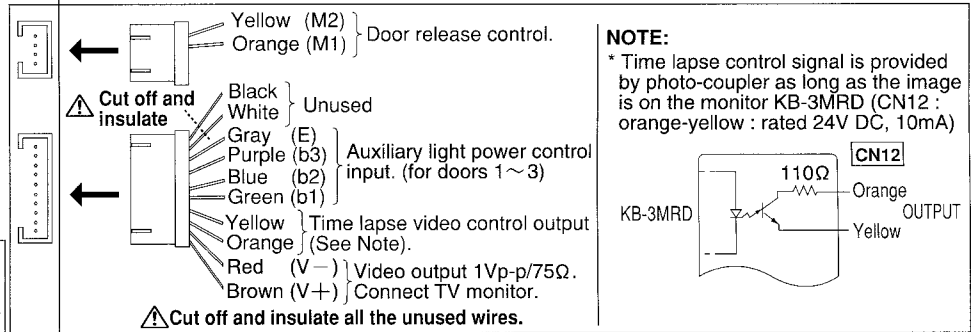

NOTE:

* Time lapse control signal is provided by photo-coupler as long as the image is on the monitor KB-3MRD (CN12 : orange-yellow : rated 24V DC, 10mA)

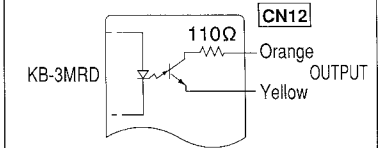

- ⚠ **Door release and auxiliary light controls are alternatively used.**
- **Auxiliary light:** When door calls, each light turns on and stays lit until the room station hangs up handset.
- **Cable:** Run audio/video wires in a pair cable. As to power supply, extend 2 wire cable separately from power supply to each monitor location.
- ⚠ **Do not use any vacant terminal for any other purpose.**

Power supply

	USA	Europe	Others
PS24 - 1	PS-24E	PS-24E	PS-24E
PS24 - 2	PS-24E or PS-2410A	PS-24E or PS-24ME	PS-24E
PS24 - 3	PS-24E or PS-2410A	PS-24E or PS-24ME	PS-24E